

# System 2024

october, unchanged issue



80 x 177 x 40 mm  
MX33FU

### Cabs MX33 (tethered only), MX33FU (2.4 GHz radio or tethered)

The shape of the ZIMO cabs (introduced in 1995 with the MX2) allows them to be used as either a table-top device or a walk-around cab. The MX33 not only comes with a design and ergonomic upgrade over the predecessor MX32 but also with a lot of potential (multiple processor performance, internal SD) for future extensions through software updates. Also: a new 2.8 inch screen, capacitive multi-touch display, additional buttons for stop and east-west (direction) handling, RGB LED's (all colors) in the keyboard, background LEDs and an optimized scroll wheel.

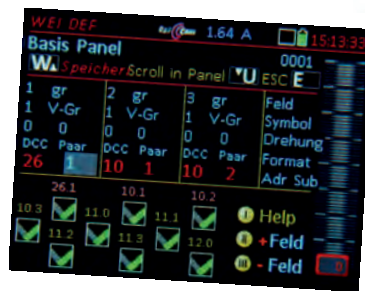
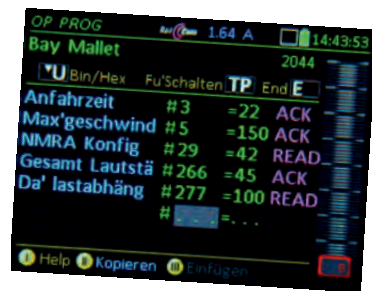

Left: Typical LOCO screen picture, speedo, functions...  
Center: other displays (small selection of 3 from @ 80) CV-Programming and read-outs in operation mode; switch panel in the set-up mode; "Stop Balls" after short circuit (UES) on track output 1.



Graphic design of the app provisional

### LOCO screen - Main display

Control and display of an active vehicle; with speed bar including HLU markings, ETCS speedometer, topic buttons and additional function keys; below the display: broadcast stop, MAN -, directional and single stop buttons.

### "Active loco recall" = Favorites

Simultaneous control of up to 5 vehicles with their own (smaller) controls, "magnifying glass" for function keys.

### The ZIMO App (in development)

Displays and controls are related to the ZIMO MX32 or MX33 cabs, but with the advantage of the large screen of smartphones or tablets. Two of the many special features of the upcoming ZIMO app are shown on the screenshots: "LoR active" (traditional ZIMO term LoR = loco recall) allows simultaneous control of up to 5 vehicles (trains); "Loco" contains a speedometer in the ETCS design (ETCS = European Train Control system), prepared for future ETCS-compliant use.

### Vehicle Database

List of directly accessible addresses (vehicles) in the app - a subset from the command station - with information about direction, speed step or actual speed and state of functions



170 x 200 x 40 mm

MX10 "big" version



MX10 Rear view



140 x 170 x 40 mm

MX10 Economy

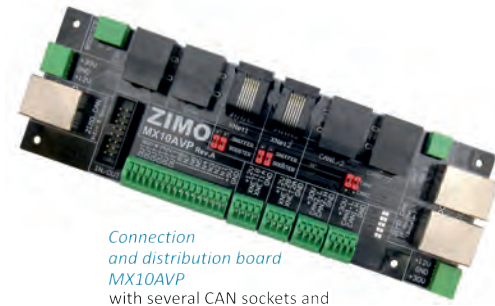

Connection and distribution board MX10AVP with several CAN sockets and terminals to expand the MX10.



WiFi router for the operation of apps on smart phone or tablet.



### Command stations: the "big" MX10, the "Economy" MX10EC

Both versions are high-performance digital centres: MX10 has two track outputs: 12 A and 8 A; MX10EC ("Economy") has „only“ one 12 A output.

The "full version" MX10 also has a built-in sound generator, more power for auxiliary voltages, more ABA pins, a USB client connector (both MX10 and MX10EC have Ethernet), and a Loconet connection (which, however, is not yet operational at the time of going to press).

Most features of MX10 and MX10EC are however identical: Finely adjustable driving voltages, overcurrent thresholds and shut-off times; short circuit spark suppression; RailCom oversampling detectors for measurement of weak signals.

The command station is using a powerful CAN bus to communicate with other system components, MIWI radio with ZIMO radio cabs, LAN (WLAN) with PC and Apps (ZIMO App, Roco App) and XpressNet for third-party products.

The ZIMO command stations are prepared for the implementation of the mfx data format. (planned, if there is enough interest)

### The ZIMO Starter sets with MX33 or MX33FU

Each starter set contains a command station, a cab, power supply and accessories (cable..):

START, -FU, -G, -GFU, -EC, -ECFU

the respective suffixes mean ...

FU = Startset comes with a radio cab MX33FU (otherwise MX33); the command station is always equipped with radio.

G.. = This starter set is intended primarily for G-scale; power supply with 600 W power (otherwise 320 W).

EC.. = This starter set comes with an economy command station MX10EC (all other sets with an MX10).

### The Starter set with the Mouse a good start, sometimes as an alternative

A START(EC)WM is a ZIMO starter set that comes with a Z21 (Roco) WLANmouse instead of a ZIMO cab. A ZIMO cab (MX33) can be added later while the mouse can be used as a useful cab at half the cost of a ZIMO cab.

### StEin expansion boards on top sockets

for 8 additional turnouts (coils, motor, servos), and 16 inputs.

## Stationary Equipment module One StEin is more than many small units

"All-in-one" INSTEAD of a collection of occupancy detectors, RailCom detectors, accessory decoders, etc.

### StEin = TRACK SECTION MODULE

Fully functional track sections with occupancy and train number detection, RailCom local/global, overcurrent (short circuit) handling and ZIMO "HLU" for route-dependent speed limits.

The combination of LZB (section control system) and PZB (milepost control) allows for exact stopping point accuracy, which means cost savings and puts the ZIMO system on the way to ETCS (European Train Control System).

### StEin = TURNOUT MODULE

for all types of turnout drives and feedback systems, two-way and three-way turnouts; comprehensive parametrisation.

### StEin = SOUND MODUL

for station announcements and all stationary railway sounds. Note: not operational at the time of going to print.

Object-orientated approach and tabular configuration recording

### StEin = SIGNAL MODULE

Signals are not connected directly, but via external "ICA boards" that are installed in the immediate vicinity of the respective signals. Up to 12 boards are powered and controlled through the I2C bus socket of each StEin: each ICA board has 16 outputs for signal LEDs.

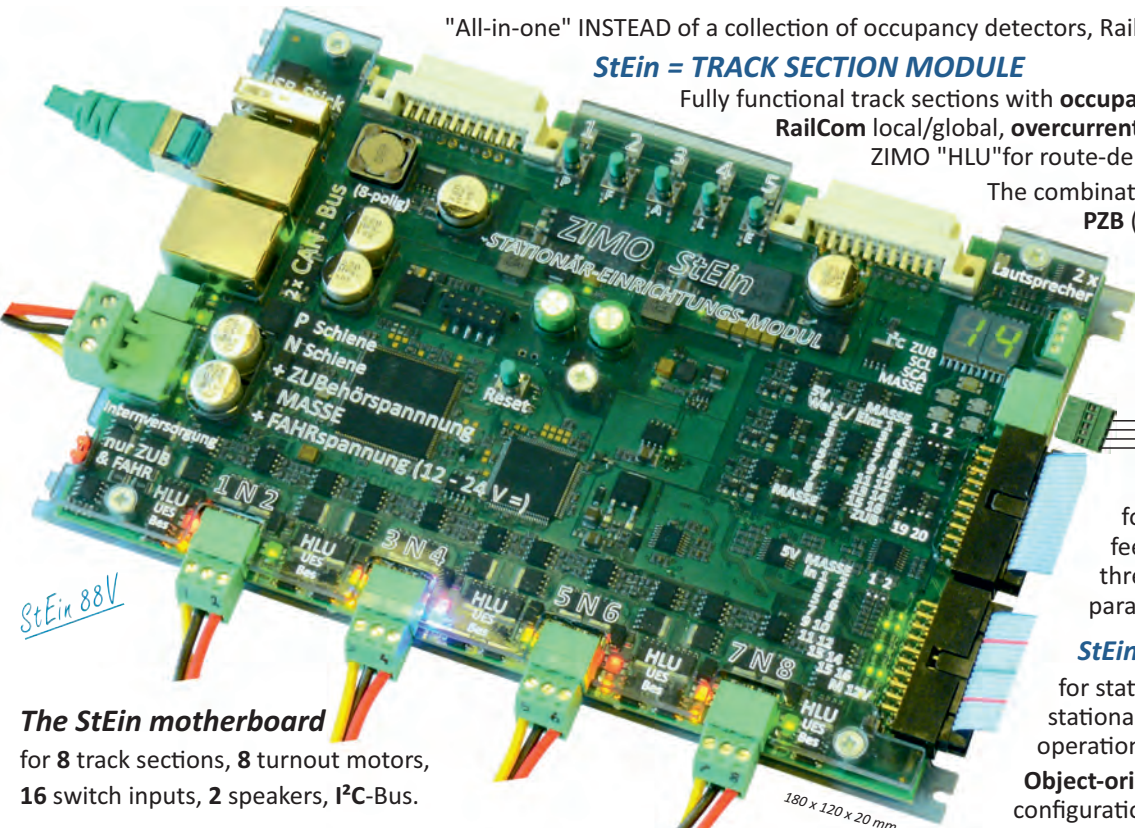

StEin 88V

### The StEin motherboard

for 8 track sections, 8 turnout motors, 16 switch inputs, 2 speakers, I2C-Bus.

180 x 120 x 20 mm

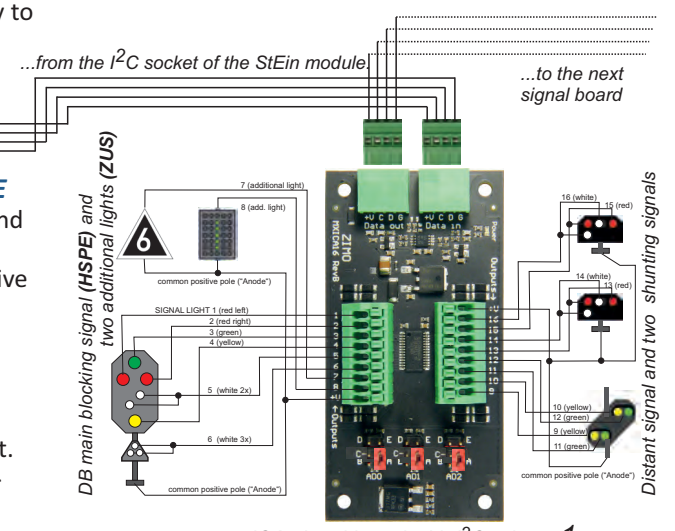

ICA signal board with I2C address 1

## The StEin

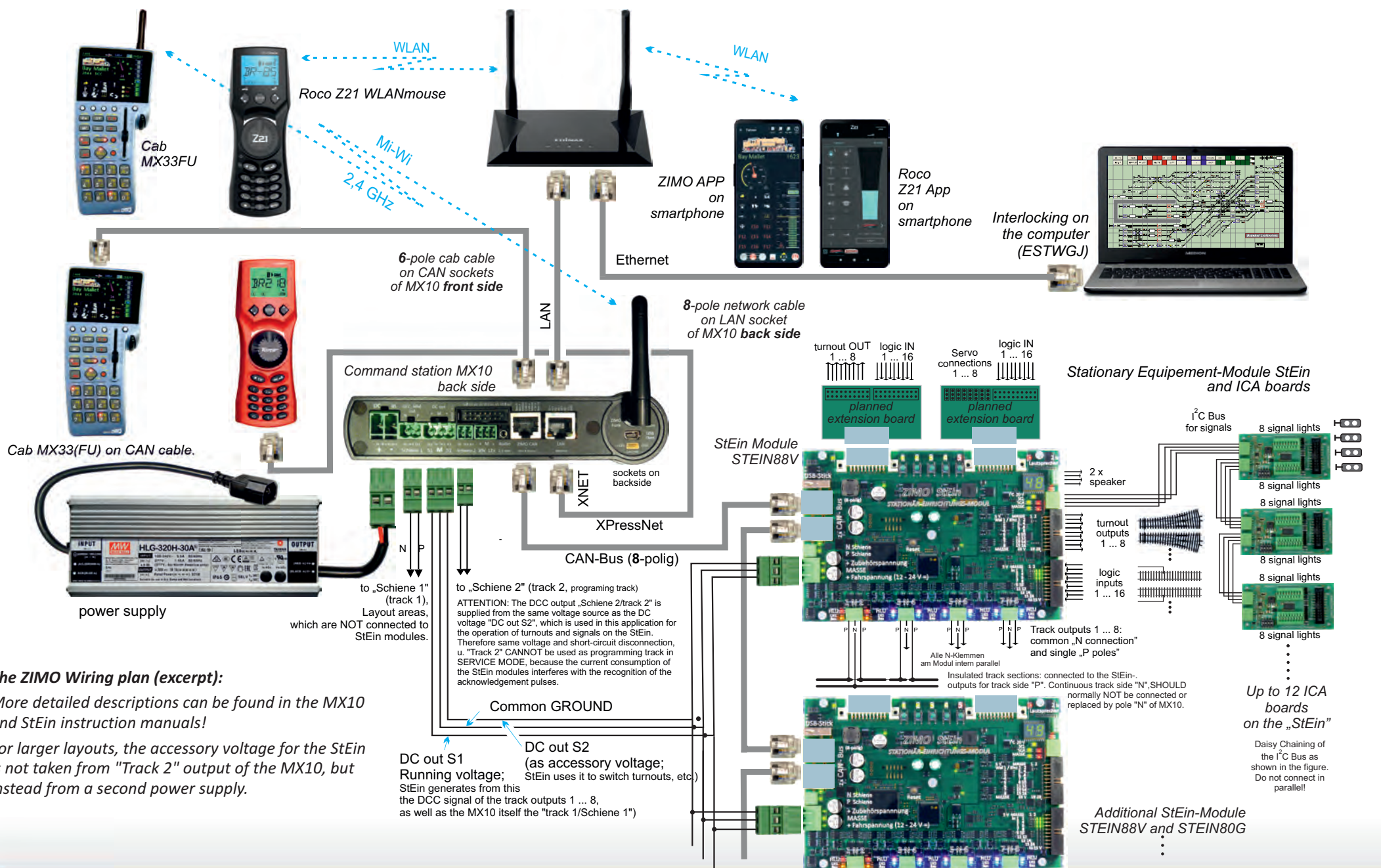

# SPECIALS

That's only with ZIMO:  
 Features that are unique, or ahead of their time, make a difference to "normal" products. Much is based on sophisticated software. The hardware contributes its share: not geared to lowest cost, but to high quality and sustainability.

HLU unmatched for 20 years

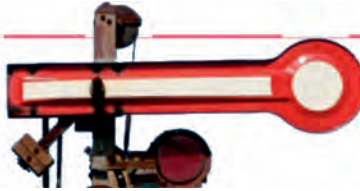

5	H Halt	7
4	UH intermediate	L
3	U Ultraslow	Level 1
2	LU intermediate	Level 2
1	L Slow	Level 3
	FL intermediate	Level 4
	F Full speed	Level 5
	(A voltage OFF)	Level 6
	The HLU speed limits	Level 7

From the beginning (1980), "HLU", initially under the designation "signal controlled speed influence", has been a fixed component of ZIMO digital systems and decoders. While DCC, according to the standard, sends **addressed commands** to each individual vehicle, **individual separate track sections** can be given **HLU information** at the same time. These are not addressed, but are location-dependent for decoders located there. In this way, trains receive HLU instructions to **stop before red signals or speed limits**. HLU information is generated by the track section outputs of a "StEin module"

The "on-track search" is used to **find the unknown address(es)** of one or a few vehicles. The vehicle currently being searched for is briefly de-energised: the address and its assigned name (if already assigned) appear in the display after a few seconds.

Autom. Registration GUI Transfer

Since the model railway runs digitally, the direction selected on the controller is not track-related but locomotive-related (Forward = "cab 1 ahead"). This is often, but not always, advantageous. ZIMO offers the possibility to drive specifically in a **given layout-related direction**, called "East" and "West", if required. Technically, this is the phasing of the DCC track signal. The characteristic feature is: the entire directional logic is NOT simply switched over, but "forward-backward" and "east-west" work together.

The current version of the **ZIMO stock search**, realized with the means of the standardized **RCN-218**, is started on the ZIMO MX33 controller; then (new) decoders report themselves; a comparison is made with the existing "object database" (the "stock"). In practice, the **ZIMO "GUI transmission"** is even more important than the registration. The "GUI" (Graphical User Interface) consists of an individual collection of images, icons and controls for each vehicle, which may also differ among operating devices (ZIMO cabs, ZIMO App, Roco App).

**ESTWGI** ESTWGI represents the **prototypical interlockings** of the German and Swiss Federal Railways, largely true to the original in their optical appearance and following their working methods. The core task is the operation, monitoring and cancellation processes based on the **safety technology** of the prototype when setting up and driving on main and shunting routes.

**ESTWGI** does not use computer game graphics for model railroad control, but offers five different "real" **interlocking representations** with different operating concepts corresponding to the respective type.

**ESTWGI** displays interlockings **on the screen** with a maximum of 199 x 99 table fields; classic interlocking control tables can also be used for system control, i.e. with real push buttons and illumination (by LEDs). Such interlocking control tables are built by the user or assembled with the help of digital components from Erbert.

**ESTWGI** also enables the monitoring of a layout with **several, independent operating stations**. This is particularly suitable for large installations (clubs, ...) where the spatial distance from station to station actually exists or is to be simulated. The communication between the interlockings runs via LAN.

**ESTWGI** uses the **"ZIMO Specials"** (see above) for layout control: HLU for **Block control** and OW (East-West) via „StEin-Modules“ (see page 1) and **milepost control** with the help of infrared switches or other detectors.

**ESTWGI** supports **automatic train control**, whereby automation (since the last extension in 2021) can be set to also trigger different routes. This is used, among other things, to change trains in hidden stations.

**ESTWGI News (excerpt 2022/23):** Level crossings in numerous variants (e.g. light signal or barrier, automated by route or security check), extensions for route blocks, network-capable fast clock, incorrect application protection and protective caps, lane tapes (graphic element for clarity in German interlockings), ...

**ESTWGI** is a product of **Heinz-Willi Grandjean**, 56154 Boppard/Rhein [www.ESTWGI.com](http://www.ESTWGI.com)



**The ESTWGI interlocking for the ZIMO N-gauge layout:**  
 The purely technical demo layout is 2 x 1.3 m big, includes 3 stations with a total of 14 tracks, 3 routes with block operation and 1 reversing loop. The electronic equipment consists of an MX10 command station with (usually) at least 2 cabs (currently MX33), and 8 StEin modules; there are special ones for the signal bridges, some with integrated accessory decoders MX820, partly with modified StEin signal boards.

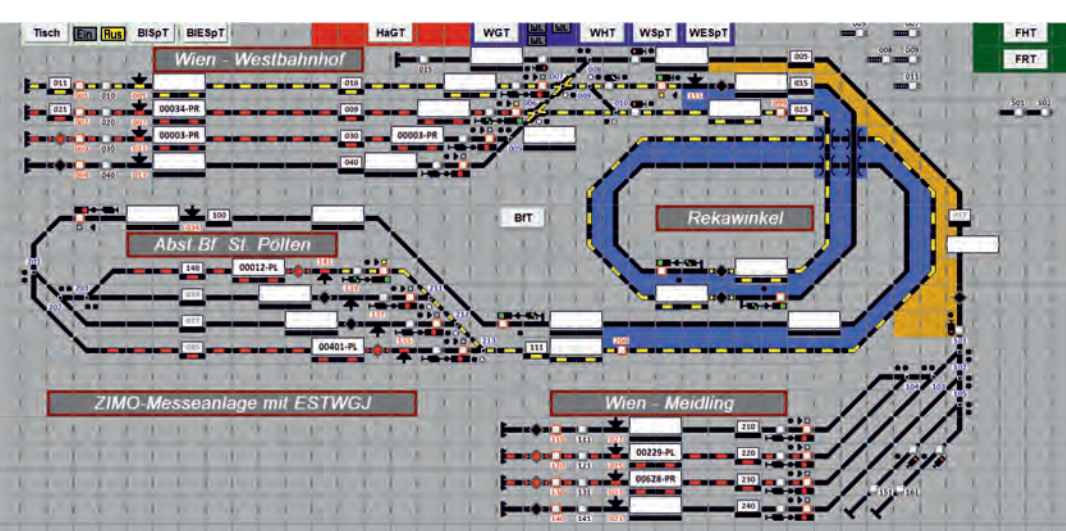

The interlocking for the N-gauge exhibition layout.

## ESTWGI

The currently available interlockings (from top to bottom):

- ESTWGI-DrL
- ESTWGI-DrS (also Slope signature)
- ESTWGI-DrS2
- ESTWGI-Dmo67

Typical ESTWGI interlockings in Switzerland and Germany:

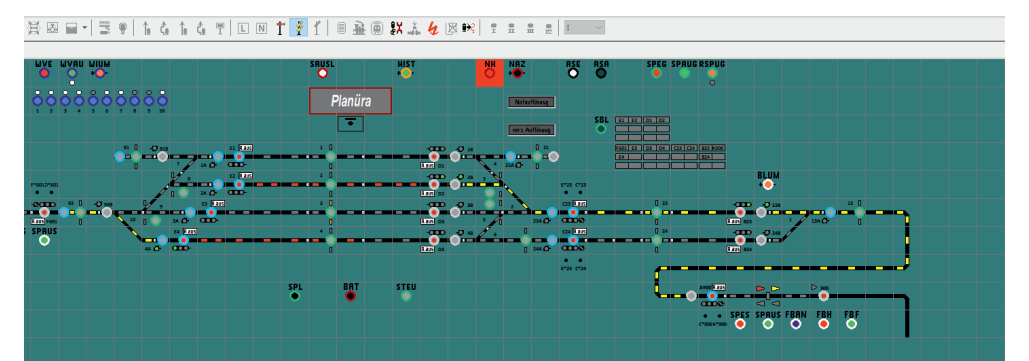

## STP 2023 News

- New interlocking type „Itlis“ (Switzerland)
- Turnout icon blanking
- Rotate / mirror multiple control panel fields
- Custom colors for control panel elements
- Detour routes (call-up via three buttons)
- Route macros
- Display of all possible routes in layout operation
- Extended information about trains on the layout
- MQTT interface [www.stp-software.at](http://www.stp-software.at)

